

Material Features:

- High-pressure die-casting aluminum case, treated with anti corrosion electrostatic powder spraying
- High temperature-proof silicon gasket, Tempered safety glass

Applicable places:

- Illumination of the Public Transport Stations, Docks, Playground, Building Sites, Parking Places, Construction sites etc.

IP65 Class I    

ELGT129-I (SYM)

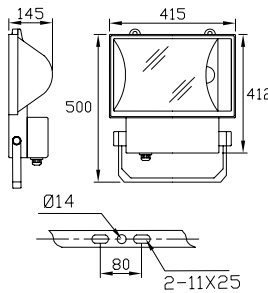

Light Distribution Curve (Cd/1000lm)

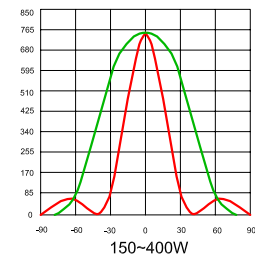

EGT129-II (SYM)

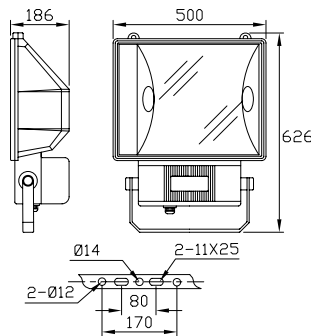

Light Distribution Curve (Cd/1000lm)

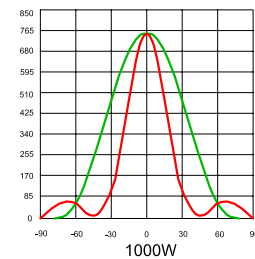

ELGT129-II (ASYM)

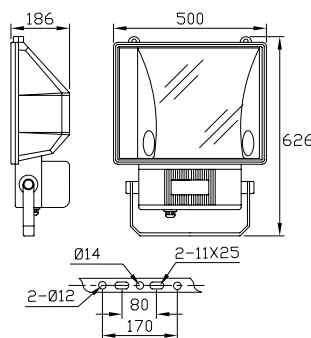

Light Distribution Curve (Cd/1000lm)

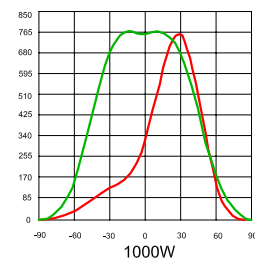

Model No	Light Source	Power W	Power factor pf	Input Voltage V/Hz	Lamp Type	Lamp Life Hr
ELGT129-I (SYM)	HPS / MH	150~400	>0.85	220~240V / 50-60Hz	E40	24000 / 12000
EGT129-II (SYM)	HPS / MH	1000	>0.85	220~240V / 50-60Hz	E40	24000 / 12000
ELGT129-II (ASYM)	HPS / MH	1000	>0.85	220~240V / 50-60Hz	E40	24000 / 12000